

motor vehicle theft claim



Lumley General Insurance Limited, ABN 24 000 036 279, Lumley House Level 9, 309 Kent Street, Sydney 2000 Ph: (02) 9248 1111 Fax: (02) 9248 1122

1. Policy Details

Policy No.	Sum insured	Excess
<input type="text"/>	<input type="text"/>	<input type="text"/>
Commencing date (dd/mm/yyyy)	Expiry date (dd/mm/yyyy)	Rating No.
<input type="text"/>	<input type="text"/>	<input type="text"/>
Claim No.		
<input type="text"/>		

2. Insured's Details

Insured's name

Residential address Postcode

Occupation

Business address Postcode

Phone number (w) Phone number (h) Mobile

3. Goods and Services Tax (G.S.T.)

To ensure you do not incur any unnecessary GST liabilities on this claim please advise your:

(a) Australian Business Number (ABN), if applicable

(b) entitlement to an Input Tax Credit in respect of:

(i) Insurance premium % and (ii) the vehicle which is the subject of this claim %

4. Vehicle Details

Make/Body type	Year	Registration No.
<input type="text"/>	<input type="text"/>	<input type="text"/>
Engine No.	Colour	Registered owner
<input type="text"/>	<input type="text"/>	<input type="text"/>

Lumley General Insurance Limited

NSW	Lumley House, Level 9, 309 Kent Street, Sydney 2000 Suite 19, 50 Glebe Road, The Junction 2291	Phone (02) 9248 1111 Phone (02) 4925 7500	Fax (02) 9248 1122 Fax (02) 4940 0295
VIC	Level 3, 99 King Street, Melbourne 3000	Phone (03) 8627 4333	Fax (03) 8627 4312
ACT	Level 4, Perpetual Building, 10 Rudd Street, Canberra City 2601	Phone (02) 6279 0333	Fax (02) 6279 0330
TAS	27 Paterson Street, Launceston 7250	Phone (03) 6345 4700	Fax (03) 6345 4711
SA	465 Pulteney Street, Adelaide 5000	Phone (08) 8228 1700	Fax (08) 8228 1777
WA	50 St George's Terrace, Perth 6000	Phone (08) 9220 8222	Fax (08) 9220 8251
QLD	Level 2, 99 Melbourne Street, South Brisbane 4101 Level 5, Northtown Tower, Flinders Mall, Townsville 4810	Phone (07) 3307 4800 Phone (07) 4722 6000	Fax (07) 3307 4899 Fax (07) 4724 4398
NT	Level 2, Beagle House, 38 Mitchell Street, Darwin 0800	Phone (08) 8946 4600	Fax (08) 8946 4666

1. Is the vehicle subject to any finance or leasing agreement?

No Yes

If no, go to question 2

Name of company

Account No.

Amount outstanding

\$

Date of last payment made (dd/mm/yyyy)

2. From who was the vehicle purchased?

Purchase price

\$

Date of purchase (dd/mm/yyyy)

3. Expiry date of registration (dd/mm/yyyy)

4. Was an anti-theft device fitted?

No Yes

If no, go to question 5

Make of device

Was it activated?

No Yes

5. Was the vehicle locked?

No Yes

6. Were the keys removed?

No Yes

7. How many sets of keys are there to the vehicle?

8. Did you ever try to sell the vehicle before its theft?

No Yes

If no, go to question 9

Give details

9. Has the vehicle had previous theft attempts? (eg. locks damaged, keys stolen)

No Yes

If no, go to question 10

Give details

10. List all the extras fitted to the vehicle

11. List all modifications made to the vehicle other than standard manufacture

12. Was there any damage to your vehicle prior to the theft?

No Yes

If no, go to question 13

Please indicate in diagram

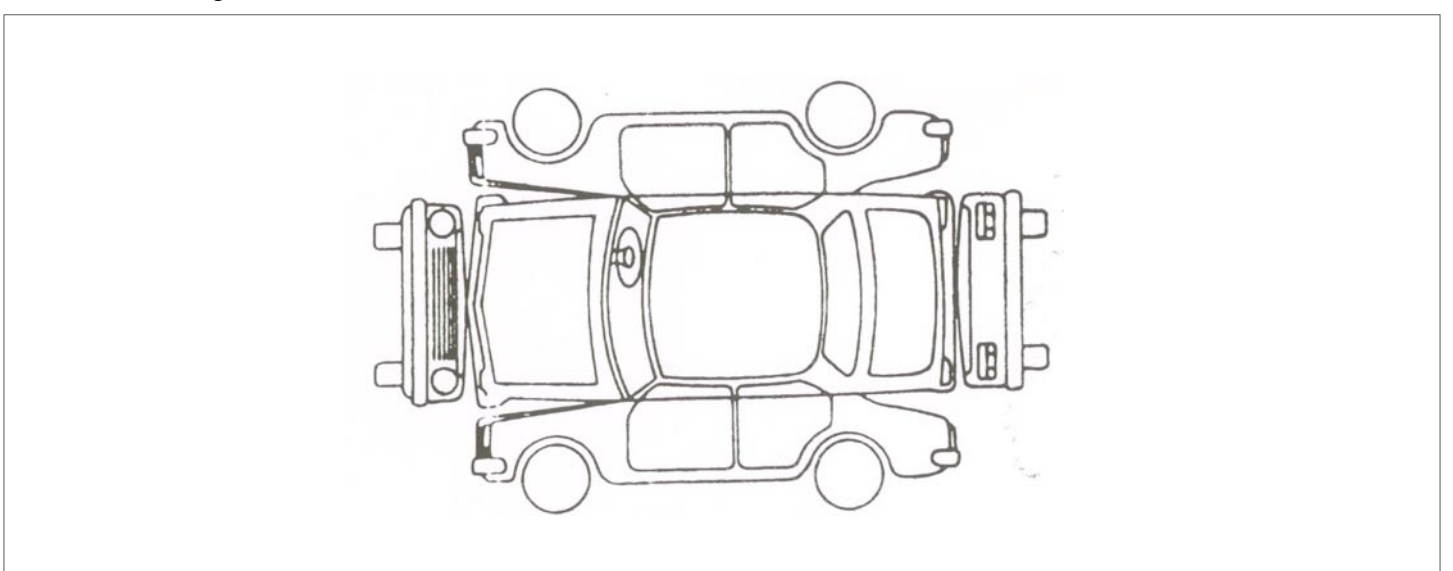

13. Date of theft (dd/mm/yyyy)

Time

 am
 pm

14. Where was your vehicle parked at time of theft? (Be specific eg. car park, on the street)

15. When was the vehicle parked there? (dd/mm/yyyy)

16. Why was the vehicle parked there?

17. Name of person in charge of vehicle at time of theft

Address

Postcode

18. Name and address of other people present when theft was discovered

Name

Address

Postcode

Name

Address

Postcode

19. How did you get home after discovering the theft?

20. To which Police Station was the theft reported?

Date of theft (dd/mm/yyyy)

Time

 am
 pm

File No.

Officers name

21. Describe in detail the events leading up to and following the theft

22. Have you made a previous theft claim?

No

Yes

If no, go to question 23

Give details

23. Who found the vehicle?

Name

Phone No (h)

Address

Postcode

24. Where was the vehicle found?

25. Date the vehicle was recovered (dd/mm/yyyy)

26. Did police attend the scene where the vehicle was recovered?

No

Yes

If no, go to question 27

Officers name

Station

27. Did you attend the scene where the vehicle was recovered?

No Yes

28. Where is the vehicle now?

29. Were any accessories or personal effects stolen or damaged from the vehicle?

No Yes

if No, please sign declaration

Description of items	Where was the item purchased	Purchase date (dd/mm/yyyy)	Amount paid	Amount claimed
<input type="text"/>	<input type="text"/>	<input type="text"/>	<input type="text"/>	<input type="text"/>
<input type="text"/>	<input type="text"/>	<input type="text"/>	<input type="text"/>	<input type="text"/>
<input type="text"/>	<input type="text"/>	<input type="text"/>	<input type="text"/>	<input type="text"/>

5. Complaints - Internal and External Complaints Procedure

If You do not agree with any decision We make in relation to Your insurance, please write to Us stating what You disagree with and why.

We will then either resolve or attempt to reesolve Your complaint immediately or refer the matter to Our Internal Dispute Resolution Committee (IDRC)

If You are not satisfied with a claim decision by the IRDC, the matter may be referred to an **independent** alternate dispute resolution body, "Insurance Enquiries and Complaints Limited" provided it falls within their jurisdiction.

6. Privacy

Lumley General Insurance Limited respects Your privacy and complies with the Privacy Act and the National Privacy Principles. A Copy of Our Privacy Policy and Procedures is available at any of Our Offices.

7. Declaration

I declare that the information supplied on this claim form is true in every respect.

I acknowledge that this Claim Form is a Legal Document and as such may be used in any Legal Proceedings resulting from this claim.

Signature of insured

Dated (dd/mm/yyyy)

Signature of last driver

Dated (dd/mm/yyyy)

Signature of witness

Dated (dd/mm/yyyy)